

AMERICAS AVIATION

www.americasaviation.com.br



2013 GULFSTREAM G280



AMERICAS AVIATION

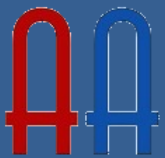

2013 GULFSTREAM G280

2.230 HORAS TOTAIS

DUAL ROCKWELL COLLINS ADC-3010

US \$ 19.550.000

Fenix Air Charter Co. 500 Ammouns Rd. Spartanburg - SC 29306 - USA - Ph. +1 757 509 5823

Av. Pres. Juscelino Kubitschek, 1830 - Itaim Bibi - São Paulo - SP - (11) 3090 3988

www.americasaviation.com.br

AMERICAS AVIATION



AMERICAS AVIATION



Fenix Air Charter Co. 500 Ammons Rd. Spartanburg - SC 29306 - USA - Ph. +1 757 509 5823
Av. Pres. Juscelino Kubitschek, 1830 - Itaim Bibi - São Paulo - SP - (11) 3090 3988
www.americasaviation.com.br



AMERICAS AVIATION





AMERICAS AVIATION



Fenix Air Charter Co. 500 Ammons Rd. Spartanburg - SC 29306 - USA - Ph. +1 757 509 5823
Av. Pres. Juscelino Kubitschek, 1830 - Itaim Bibi - São Paulo - SP - (11) 3090 3988
www.americasaviation.com.br

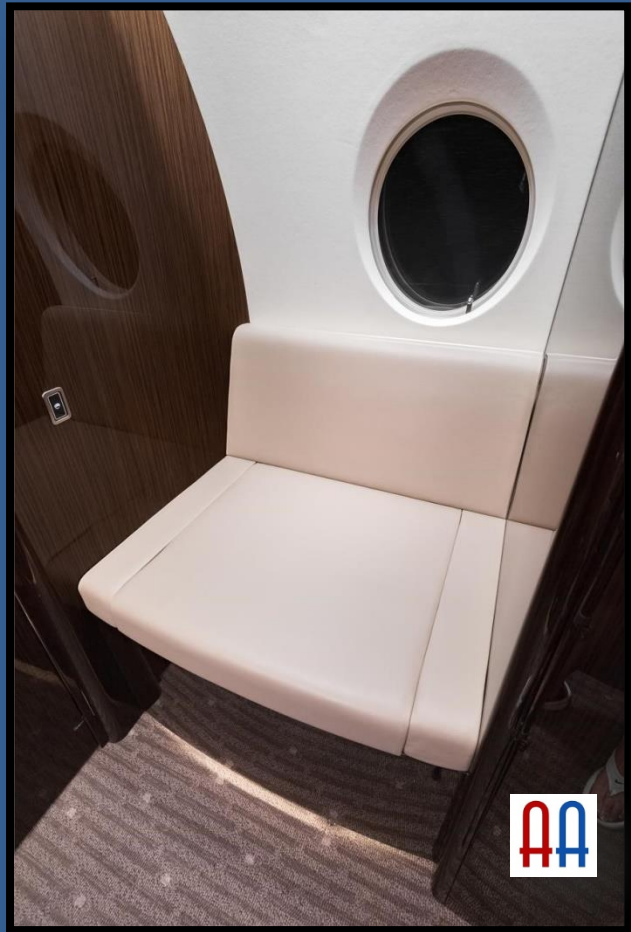
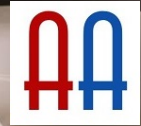

Fenix Air Charter Co. 500 Ammons Rd. Spartanburg - SC 29306 - USA - Ph. +1 757 509 5823
Av. Pres. Juscelino Kubitschek, 1830 - Itaim Bibi - São Paulo - SP - (11) 3090 3988
www.americasaviation.com.br



AMERICAS AVIATION



AMERICAS AVIATION

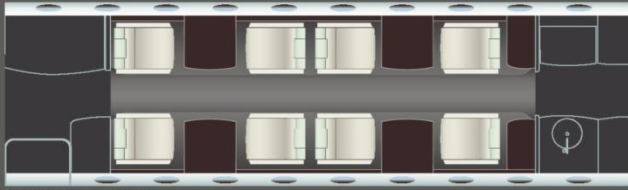

8 PASSENGER FLOORPLAN

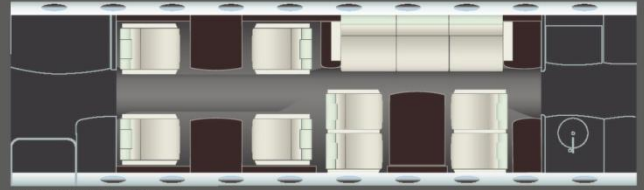

10 PASSENGER FLOORPLAN

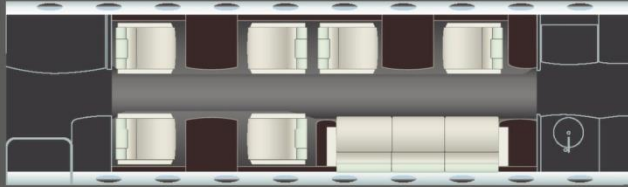

9 PASSENGER FLOORPLAN

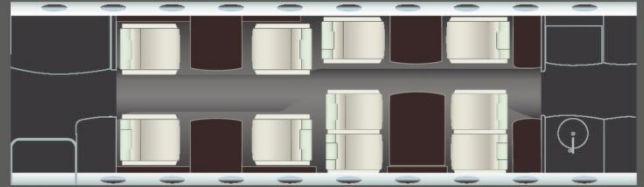

10 PASSENGER FLOORPLAN

FLEXIBILITY *comes* STANDARD

Tailor your aircraft cabin to your mission profiles. Whether flying a team of experts to a business meeting or the family on a vacation retreat, Gulfstream's cabin design process offers flexibility to help you create your own interior masterpiece. Find a new favorite room in your Gulfstream jet.

AMERICAS AVIATION



www.the-blueprints.com

Fenix Air Charter Co. 500 Ammouns Rd. Spartanburg - SC 29306 - USA - Ph. +1 757 509 5823
Av. Pres. Juscelino Kubitschek, 1830 - Itaim Bibi - São Paulo - SP - (11) 3090 3988
www.americasaviation.com.br

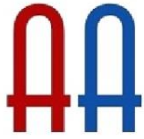

Gulfstream G280

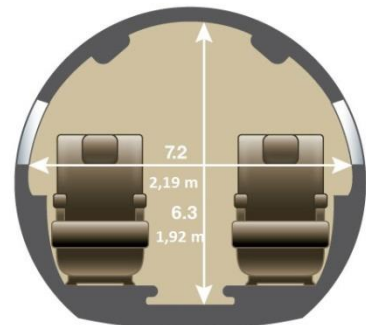
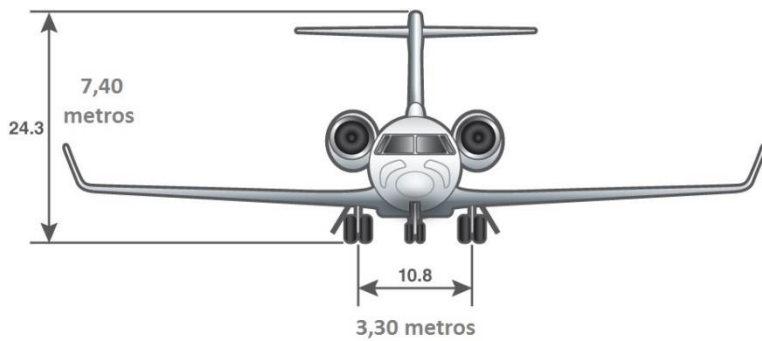
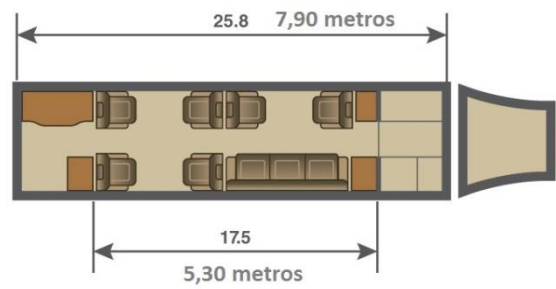
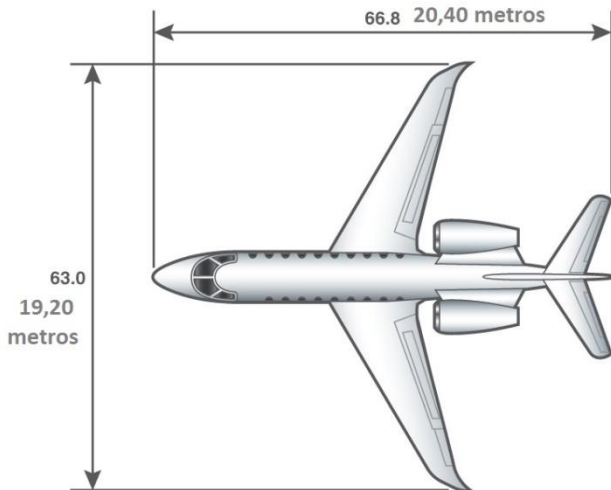
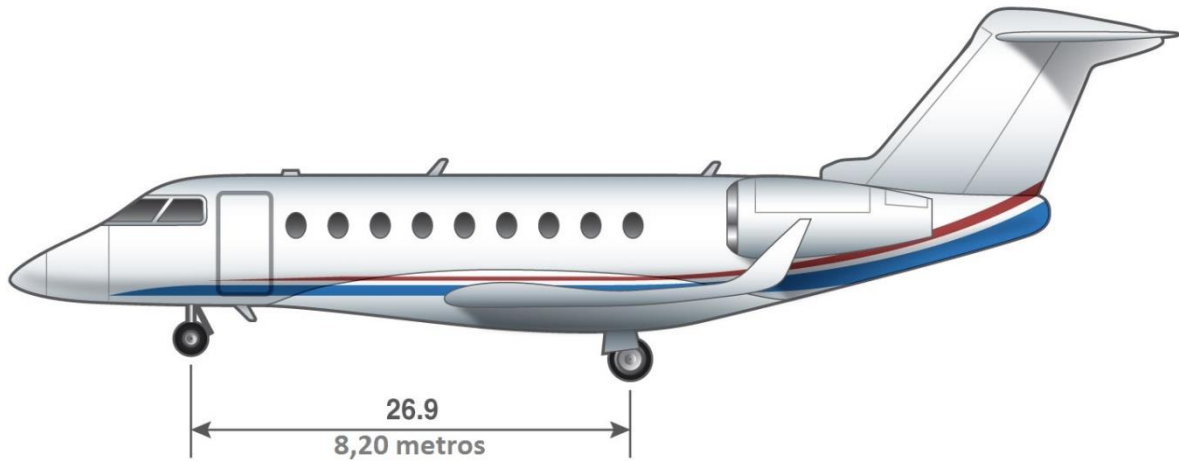

Gulfstream G280

O G280 da Gulfstream é superior na maioria das áreas do mercado de jatos executivos de médio porte com excelente desempenho, conforto e tecnologia avançada. O G280 tem o maior alcance na velocidade de cruzeiro mais rápida entre os jatos super médios. Seu excelente desempenho de campo permite o acesso da aeronave a alguns dos aeroportos mais difíceis.

Airframe STATUS: As of June 30, 2018

TOTAL TIME: 2230.7

LANDINGS: 1473

ENGINES: Honeywell AS907-2-1G

Engine 1 Manufacturer HONEYWELL

Engine 2 Manufacturer HONEYWELL

Engine 1 Model AS907-2-1G

Engine 2 Model AS907-2-1G

APU Maintenance Program MSP

Engine(s) LEFT

Total Time Since New: 2230.7

Cycles Since New: 1475

MPI Due (HRS): 4000

CZI Due (HRS): 8000

SERIAL NUMBER: P-130159

RIGHT

Total Time Since New: 2230.7

Cycles Since New: 1475

MPI Due (HRS): 4000

CZI Due (HRS): 8000
SERIAL NUMBER: P-130158

Engines are enrolled on MSP Gold

APU: GTCP 36-150
Serial Number: P-124
TSN: 908

APU is enrolled on MSP Gold

Avionics Packaging Rockwell-Collins
ADS-B Equipped
FANS
CPDLC

Avionics/Radios

AIR DATA COMPUTER: Dual Rockwell Collins ADC-3010
Air Data Computers
AUTOTHROTTLES: Gulfstream Auto Throttles
COCKPIT VOICE RECORDER: Multi-Purpose CVR/FDR
(25 Hour Continuous Loop)
COMMUNICATIONS: Triple Rockwell Collins VHF-4000E
VHF Transceivers
DISTANCE MEASURING EQUIPMENT: Dual Rockwell
Collins DME-4000 Distance Measuring Equipment
EMERGENCY LOCATOR TRANSMITTER: Artex C406-N
ELT
GLOBAL POSITIONING SYSTEM: Dual Rockwell Collins
GPS-4000S Global Positioning System
GRAPHICAL WEATHER: XM Satellite Weather

HIGH FREQUENCY COMMUNICATION: Dual Rockwell Collins HF-9031A HF Transceivers
INERTIAL REFERENCE SYSTEM: Dual Honeywell Laseref VI Micro Inertial Reference Unit
NAVIGATION: Rockwell Collins NAV-4000 and NAV-4500 VOR/ILS/ADF/MB Navigation Receiver
RADAR: Rockwell Collins RTA-4118 Weather Radar
RADIO ALTIMETER: Single Rockwell Collins ALT-4000 Radio Altimeter
TERRAIN AWARENESS WARNING SYSTEM: Rockwell Collins Integrated TAWS System
TRAFFIC COLLISION AVOIDANCE SYSTEM: Rockwell Collins TSS-4100 TCAS
TRANSPONDER: Rockwell Collins Transponder
Additional Equipment
Wifi

Exterior

Year Painted 2013

Matterhorn White with Brown Striping

Interior

Year Interior 2013

Number of Seats 10

Galley Configuration Forward

Lavatory Configuration Aft

Interior

Beautiful ten passenger cabin features a four-club seat configuration with two-fold out tables in the forward cabin.

Aft cabin features a three-place divan (two places certified for take-off) across from a four-person conference area. In addition, the aircraft has a forward galley, aft lavatory, and a jump seat in the cockpit.

Inspection Status - INSPECTION / NEXT DUE

24 Month Inspection-----September 2019

36 Month Inspection-----September 2019

48 Month Inspection-----September 2021

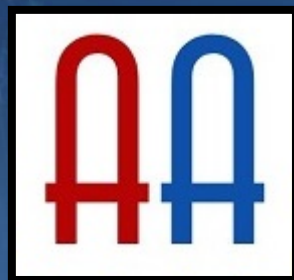

Fenix Air Charter Co. 500 Ammouns Rd. Spartanburg - SC 29306 - USA - Ph. +1 757 509 5823

Av. Pres. Juscelino Kubitschek, 1830 - Itaim Bibi - São Paulo - SP - (11) 3090 3988

www.americasaviation.com.br